

Linear programming

- Example Numpy: PageRank
- `scipy.optimize.linprog`
- Example linear programming: Maximum flow

PageRank

PageRank - A NumPy / Jupyter / matplotlib example

- Google's original search engine ranked webpages using **PageRank**
- View the internet as a graph where **nodes** correspond to webpages and **directed edges** to links from one webpage to another webpage
- Google's PageRank algorithm was described in (ilpubs.stanford.edu:8090/361/, 1998)

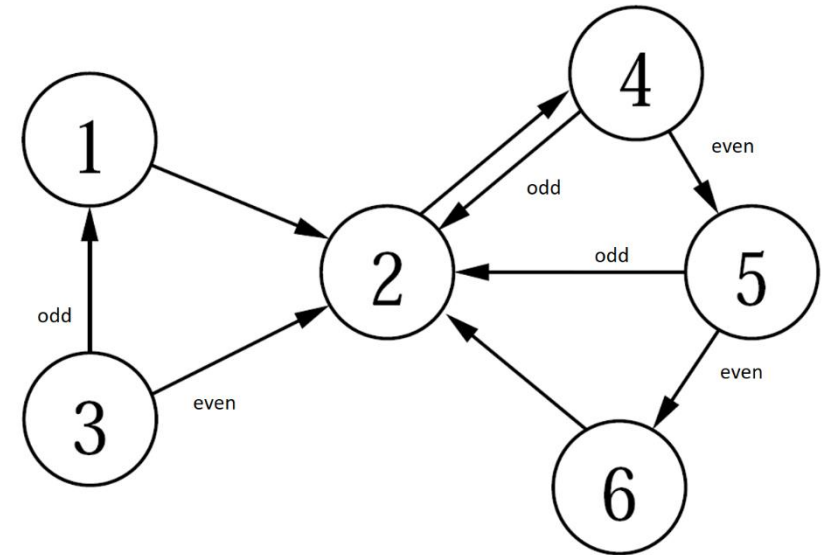

The Anatomy of a Large-Scale Hypertextual Web Search Engine

Sergey Brin and Lawrence Page

*Computer Science Department,
Stanford University, Stanford, CA 94305, USA*
sergey@cs.stanford.edu and page@cs.stanford.edu

Five different ways to compute PageRank probabilities

- 1) Simulate random process manually by rolling dices
- 2) Simulate random process in Python
- 3) Computing probabilities using matrix multiplication
- 4) Repeated matrix squaring
- 5) Eigenvector for $\lambda = 1$

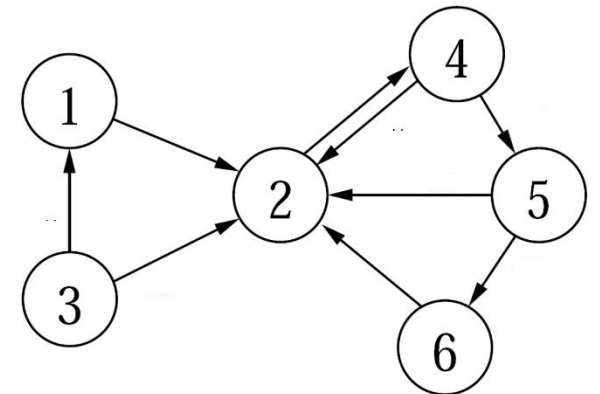

Random surfer model (simplified)

The PageRank of a node (web page) is the fraction of the time one visits a node by performing an *infinite random traversal* of the graph starting at node 1, and in each step

- with **probability 1/6** jumps to a **random page** (probability 1/6 for each node)
- with **probability 5/6** follows an **outgoing edge** to an adjacent node (selected uniformly)

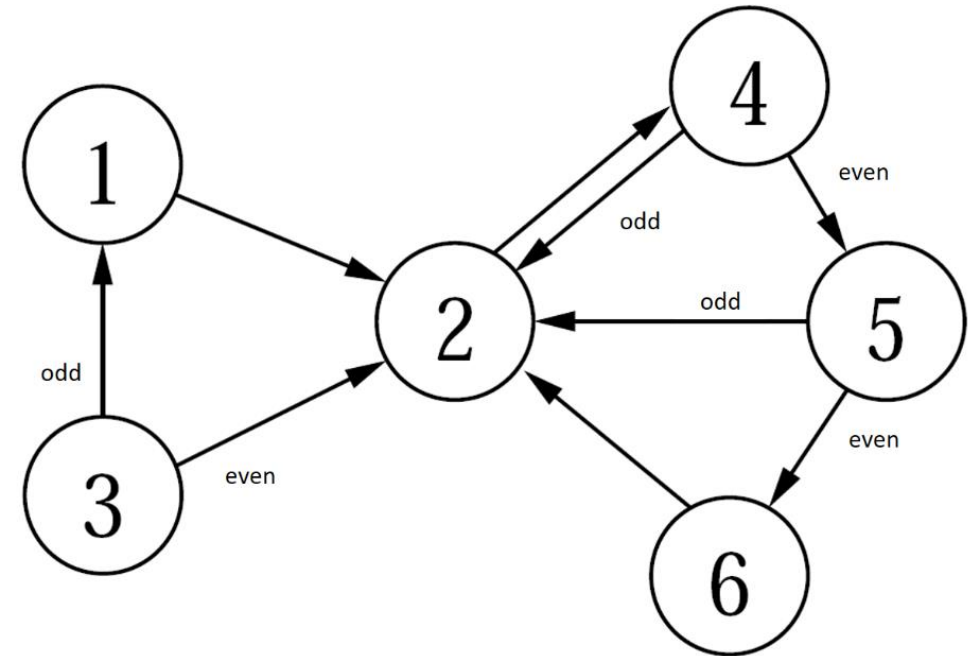

The above can be simulated by using a dice: Roll a *dice*. If it shows 6, jump to a random page by rolling the dice again to figure out which node to jump to. If the dice shows 1-5, follow an outgoing edge - if two outgoing edges roll the dice again and go to the lower number neighbor if it is odd.

Adjacency matrix and degree vector

pagerank.ipynb

```
import numpy as np

# Adjacency matrix of the directed graph in the figure
# (note that the rows/columns are 0-indexed, whereas in the figure the nodes are 1-indexed)

G = np.array([[0, 1, 0, 0, 0, 0],
              [0, 0, 0, 1, 0, 0],
              [1, 1, 0, 0, 0, 0],
              [0, 1, 0, 0, 1, 0],
              [0, 1, 0, 0, 0, 1],
              [0, 1, 0, 0, 0, 0]])

n = G.shape[0] # number of rows in G
degree = np.sum(G, axis=1, keepdims=True) # column vector with row sums = out-degrees

# The below code handles sinks, i.e. nodes with outdegree zero (no effect on the graph above)

G = G + (degree == 0) # add edges from sinks to all nodes
degree = np.sum(G, axis=1, keepdims=True)
```

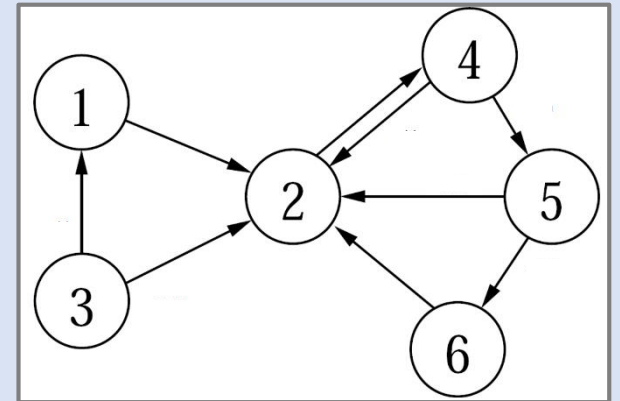

Simulate random walk (random surfer model)

pagerank.ipynb

```
from random import randint
STEPS = 1000000
# adjacency_list[i] is a list of all j where (i, j) is an edge of the graph.
adjacency_list = [[j for j, e in enumerate(row) if e] for row in G]
count = np.zeros(n)          # histogram over number of node visits
state = 0                    # start at node with index 0
for _ in range(STEPS):
    count[state] += 1        # increment count for state
    if randint(1, 6) == 6:   # original paper uses 15% instead of 1/6
        state = randint(0, 5)
    else:
        state = adjacency_list[state][randint(0, degree[state] - 1)]
print(adjacency_list, count / STEPS, sep='\n')
```

Python shell

```
| [[1], [3], [0, 1], [1, 4], [1, 5], [1]]
| [0.039365 0.353211 0.02751 0.322593 0.1623 0.095021]
```

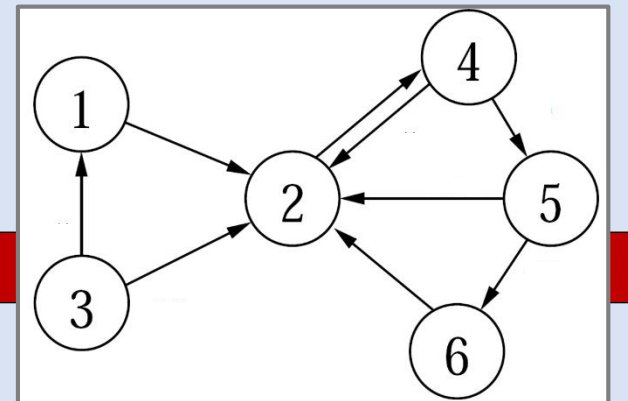

Simulate random walk (random surfer model)

pagerank.ipynb

```
import matplotlib.pyplot as plt
plt.bar(range(6), count)
plt.title("Random Walk")
plt.xlabel("node")
plt.ylabel("number of visits")
plt.show()
```

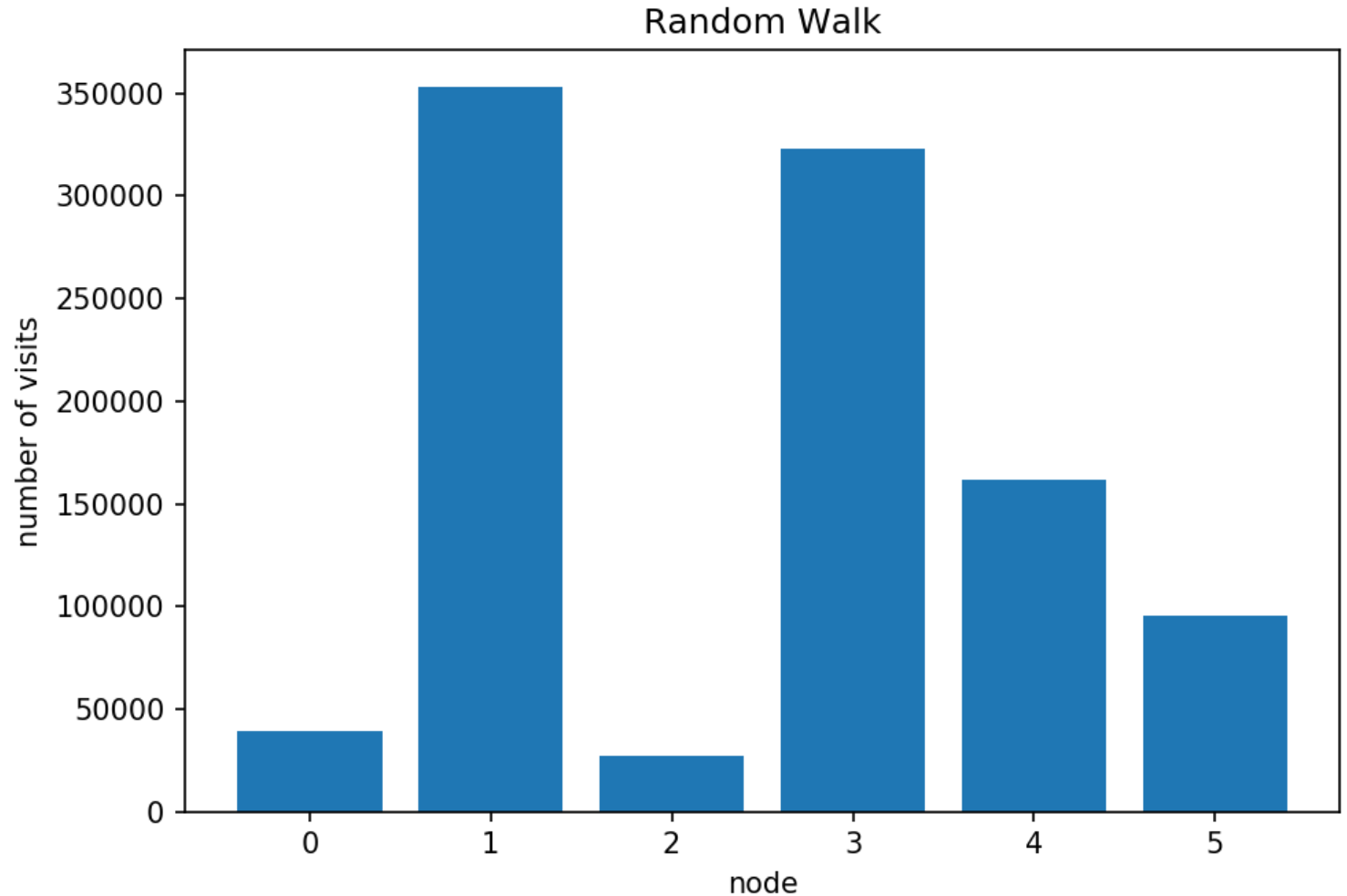
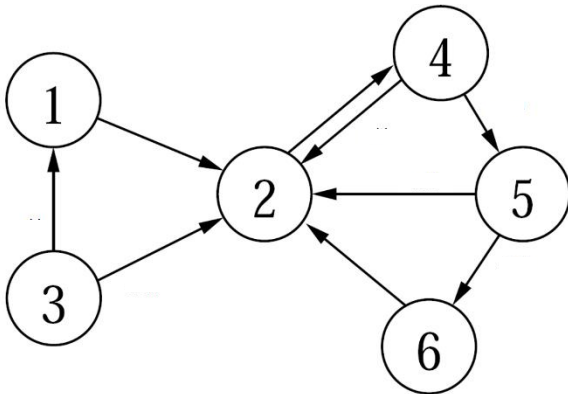

Transition matrix A

```
pagerank.ipynb
```

```
A = G / degree # Normalize row sums to one. Note that 'degree'  
                # is an n x 1 matrix, whereas G is an n x n matrix.  
                # The elementwise division is repeated for each column of G  
print(A)
```

```
Python shell
```

```
| [[0.  1.  0.  0.  0.  0. ]  
  [0.  0.  0.  1.  0.  0. ]  
  [0.5 0.5 0.  0.  0.  0. ]  
  [0.  0.5 0.  0.  0.5 0. ]  
  [0.  0.5 0.  0.  0.  0.5]  
  [0.  1.  0.  0.  0.  0. ]]
```

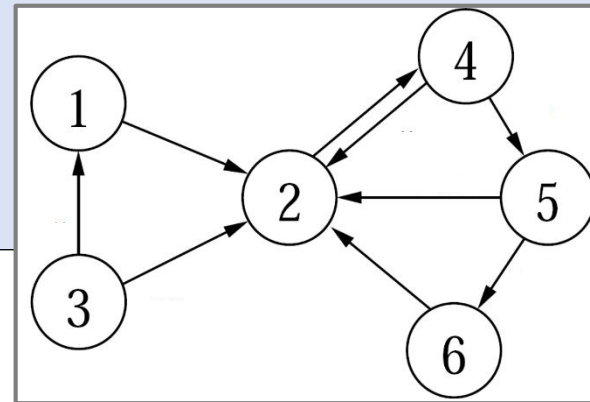

Repeated matrix multiplication

We now want to compute the **probability** $p_j^{(i)}$ to be in vertex j after i steps. Let $p^{(i)} = (p_0^{(i)}, \dots, p_{n-1}^{(i)})$.

Initially we have $p^{(0)} = (1, 0, \dots, 0)$.

We compute a matrix M , such that $p^{(i)} = M^i \cdot p^{(0)}$ (assuming $p^{(0)}$ is a column vector).

If we let $\mathbf{1}_n$ denote the $n \times n$ matrix with 1 in each entry, then M can be computed as:

$$p_j^{(i+1)} = \frac{1}{6} \cdot \frac{1}{n} + \frac{5}{6} \sum_k p_k^{(i)} \cdot A_{k,j}$$

$$p^{(i+1)} = \underbrace{\left(\frac{1}{6} \cdot \frac{1}{n} \mathbf{1}_n + \frac{5}{6} A^T \right)}_M \cdot p^{(i)}$$

pagerank.ipynb

```
ITERATIONS = 20
p_0 = np.zeros((n, 1))
p_0[0, 0] = 1.0
M = 1 / (6 * n) + 5 / 6 * A.T
p = p_0
prob = p # 'prob' will contain each
          # computed 'p' as a new column
for _ in range(ITERATIONS):
    p = M @ p
    prob = np.append(prob, p, axis=1)
print(p)
```

Python shell

```
| [[0.03935185]
  [0.35326184]
  [0.02777778]
  [0.32230071]
  [0.16198059]
  [0.09532722]]
```

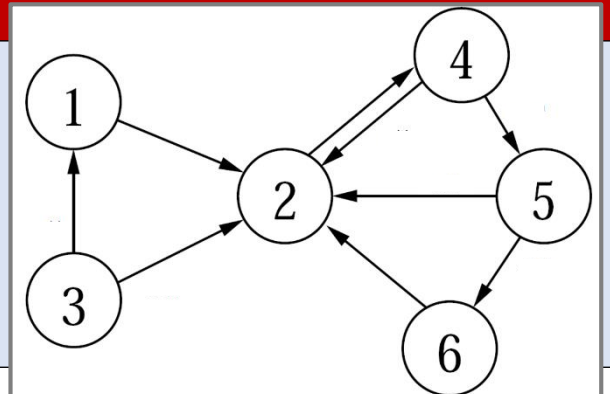

Rate of convergence

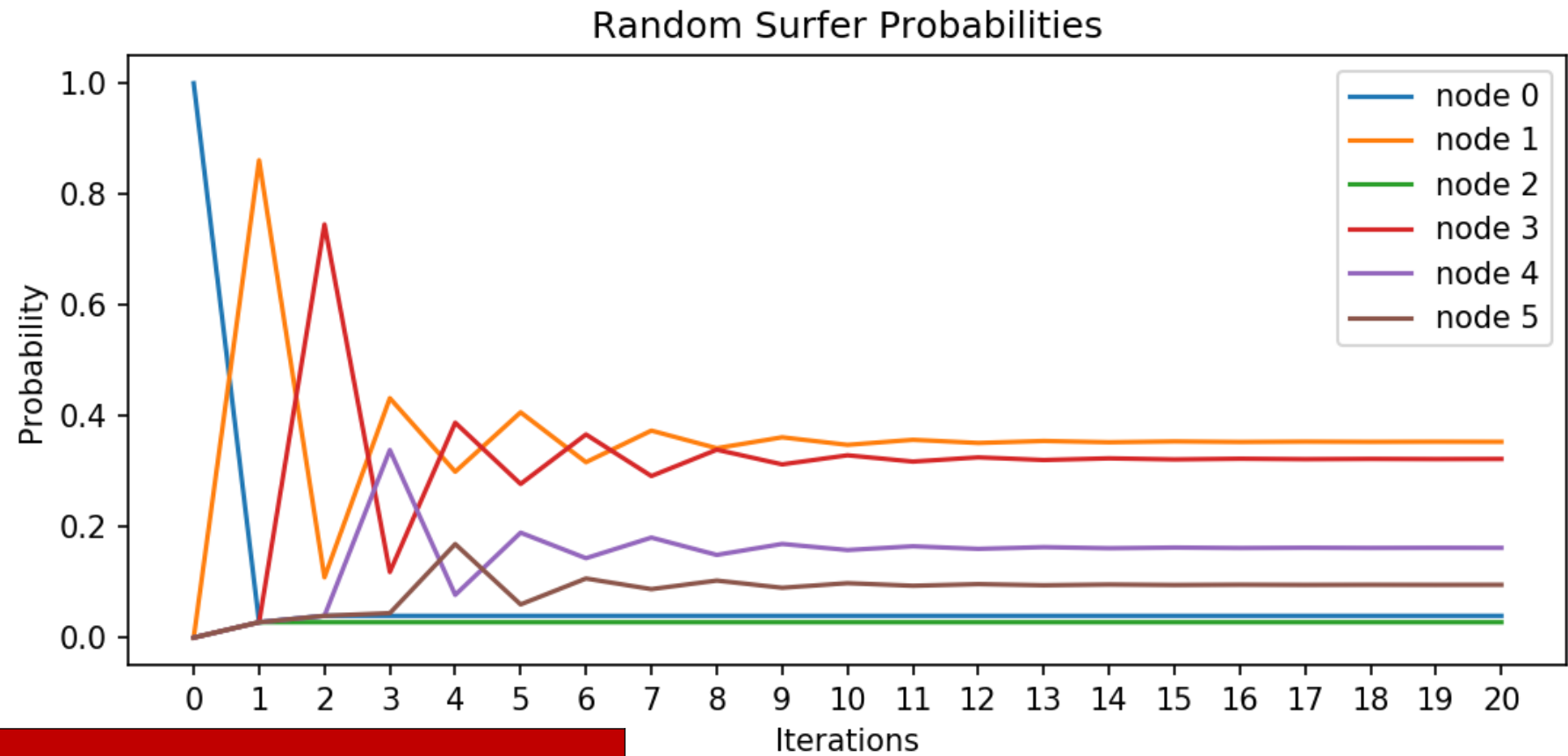

pagerank.ipynb

```
x = range(ITERATIONS + 1)
for node in range(n):
    plt.plot(x, prob[node], label="node %s" % node)
plt.xticks(x)
plt.title("Random Surfer Probabilities")
plt.xlabel("Iterations")
plt.ylabel("Probability")
plt.legend()
plt.show()
```

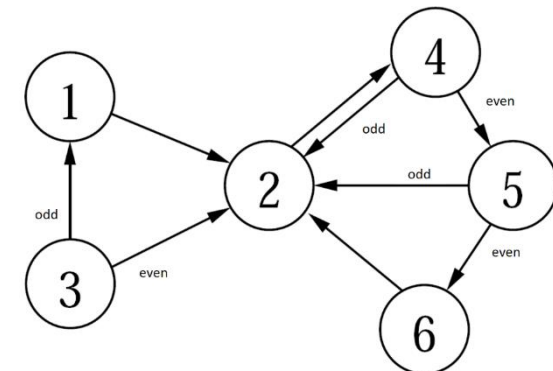

Repeated squaring

$$\underbrace{M \cdot (\dots (M \cdot (M \cdot p^{(0)})) \dots)}_{k \text{ multiplications, } k \text{ power of } 2} = M^k \cdot p^{(0)} = M^{2^{\log k}} \cdot p^{(0)} = (\dots ((M^2)^2)^2 \dots)^2 \cdot p^{(0)}$$

k multiplications, k power of 2

pagerank.ipynb

```
from math import log
MP = M
for _ in range(1 + int(log(ITERATIONS, 2))):
    MP = MP @ MP
p = MP @ p_0
print(p)
```

Python shell

```
| [[0.03935185]
  [0.35332637]
  [0.02777778]
  [0.32221711]
  [0.16203446]
  [0.09529243]]
```

PageRank : Computing eigenvector for $\lambda = 1$

- We want to find a vector p , with $|p| = 1$, where $Mp = p$, i.e. an *eigenvector* p for the eigenvalue $\lambda = 1$

```
pagerank.ipynb
```

```
eigenvalues, eigenvectors = np.linalg.eig(M)
idx = eigenvalues.argmax() # find the largest eigenvalue (= 1)
p = np.real(eigenvectors[:, idx]) # .real returns the real part of complex numbers
p /= p.sum() # normalize p to have sum 1
print(p)
```

```
Python shell
```

```
| [0.03935185 0.3533267 0.02777778 0.32221669 0.16203473 0.09529225]
```

PageRank : Note on practicality

- In practice an explicit matrix for billions of nodes is infeasible, since the number of entries would be order of 10^{18}
- Instead use **sparse matrices** (in Python modul `scipy.sparse`) and stay with repeated multiplication

Linear programming

scipy.optimize.linprog

- `scipy.optimize.linprog` can solve *linear programs* of the following form, where one wants to find an $n \times 1$ vector x satisfying:

Minimize: $c^T \cdot x$

Subject to: $A_{ub} \cdot x \leq b_{ub}$
 $A_{eq} \cdot x = b_{eq}$

dimension

$c : n \times 1$

$A_{ub} : m \times n$

$b_{ub} : m \times 1$

$A_{eq} : k \times n$

$b_{eq} : k \times 1$

Linear programming example

Maximize

$$3 \cdot x_1 + 2 \cdot x_2$$

Subject to

$$2 \cdot x_1 + 1 \cdot x_2 \leq 10$$

$$5 \cdot x_1 + 6 \cdot x_2 \geq 4$$

$$-3 \cdot x_1 + 7 \cdot x_2 = 8$$



Minimize

$$-(3 \cdot x_1 + 2 \cdot x_2)$$

Subject to

$$2 \cdot x_1 + 1 \cdot x_2 \leq 10$$

$$-5 \cdot x_1 + -6 \cdot x_2 \leq -4$$

$$-3 \cdot x_1 + 7 \cdot x_2 = 8$$

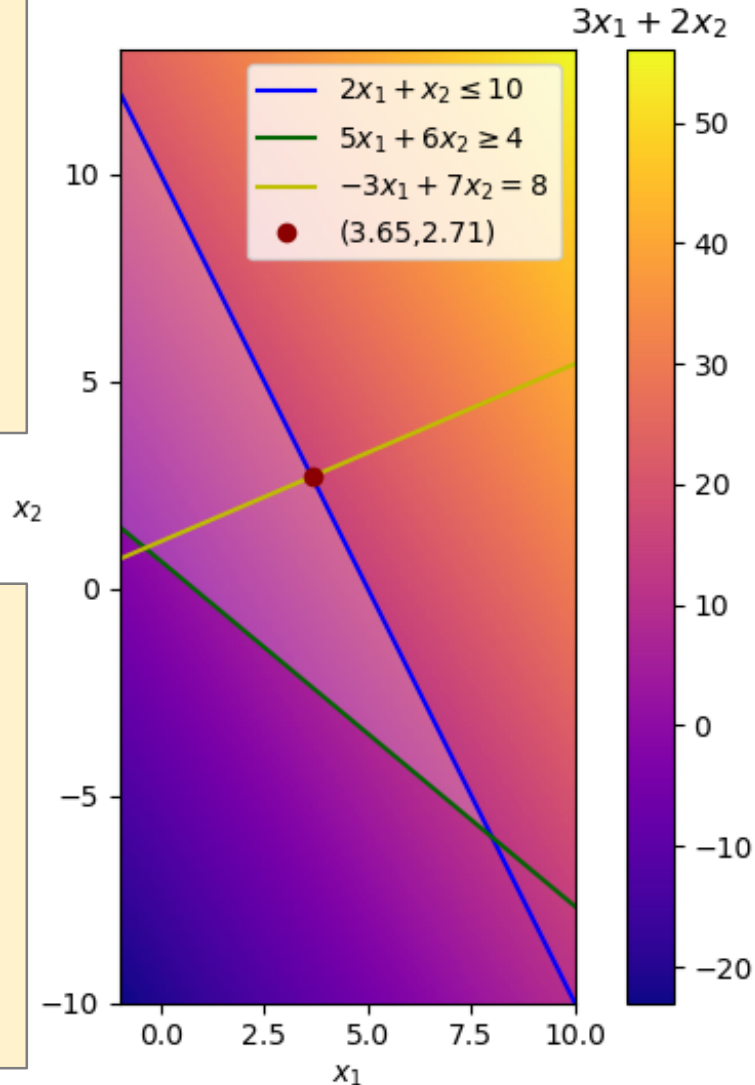

linear_programming.py

```
import numpy as np
from scipy.optimize import linprog
c = np.array([3, 2])
A_ub = np.array([[ 2,  1],
                 [-5, -6]]) # multiplied by -1
b_ub = np.array([10, -4])
A_eq = np.array([[ -3,  7]])
b_eq = np.array([8])
res = linprog(-c, # maximize = minimize the negated
              A_ub=A_ub,
              b_ub=b_ub,
              A_eq=A_eq,
              b_eq=b_eq)
print(res) # res.x is the optimal vector
```

Python shell

```
fun: -16.35294117647059
message: 'Optimization terminated successfully.'
nit: 3
slack: array([ 0.          , 30.47058824])
status: 0
success: True
x: array([3.64705882, 2.70588235])
```

Maximum flow

Solving maximum flow using linear programming

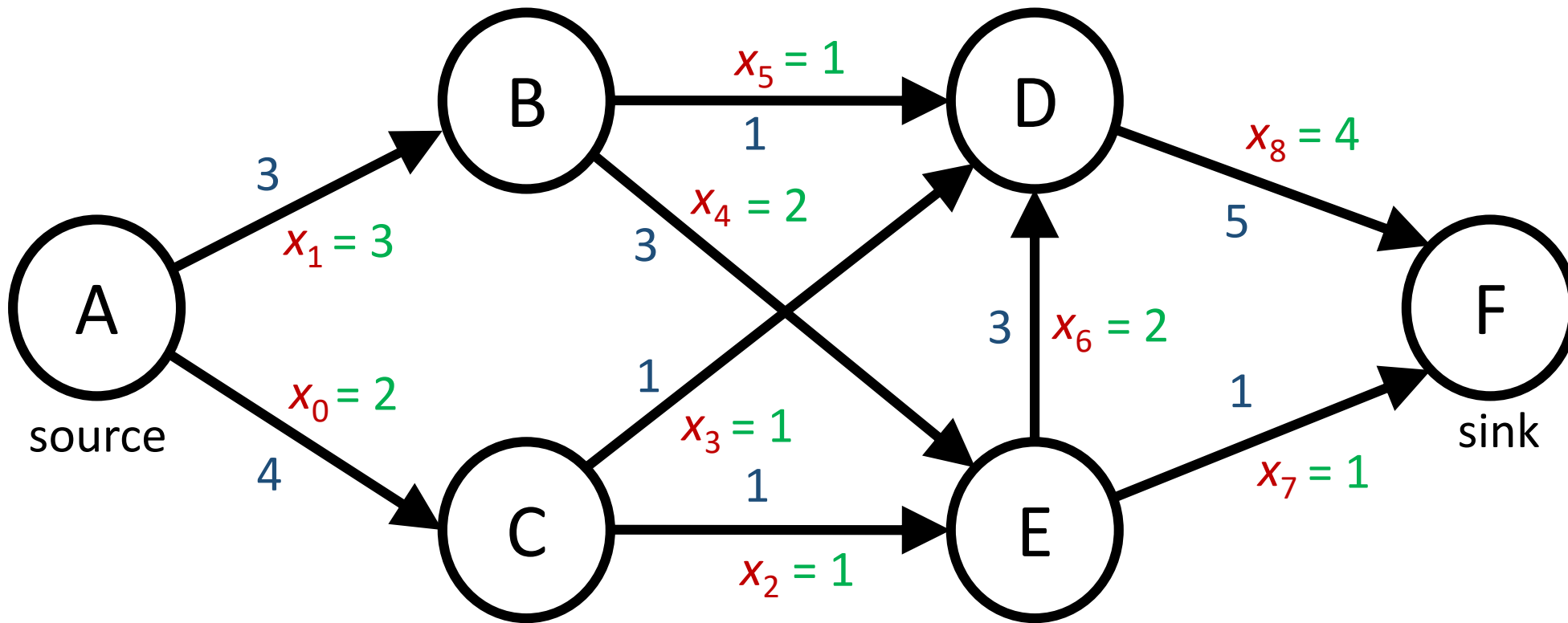

Maximize	$x_7 + x_8$	flow value
Subject to		
	$x_0 \leq 4$	} capacity constraints
	$x_1 \leq 3$	
	$x_2 \leq 1$	
	$x_3 \leq 1$	
	$x_4 \leq 3$	
	$x_5 \leq 1$	
	$x_6 \leq 3$	
	$x_7 \leq 1$	
	$x_8 \leq 5$	} flow conservation
	$x_1 = x_4 + x_5$	
	$x_0 = x_2 + x_3$	
	$x_3 + x_5 + x_6 = x_8$	
	$x_2 + x_4 = x_6 + x_7$	

We will use the `scipy.optimize.linprog` function to solve the *maximum flow* problem on the above directed graph. We want to send as much *flow* from node A to node F. Edges are numbered 0..8 and each edge has a maximum *capacity*.

Note: solution not unique

Solving maximum flow using linear programming

- x is a vector describing the flow along each edge
- c is a vector that to add the flow along the edges (7 and 8) to the sink (F), i.e. a function computing *the flow value*
- A_{ub} and b_{ub} is a set of *capacity constraints*, for each edge flow \leq capacity
- A_{eq} and b_{eq} is a set of *flow conservation* constraints, for each non-source and non-sink node (B, C, D, E), requiring that the flow into equals the flow out of a node

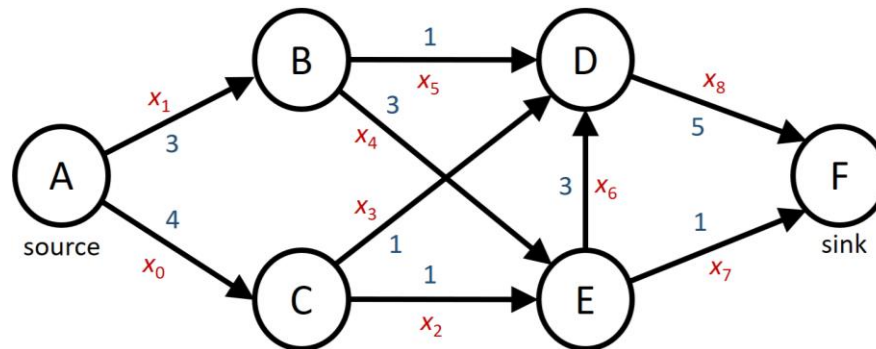

Maximize

$x_7 + x_8$ $c^T \cdot x$ flow value

Subject to

$x_0 \leq 4$
 $x_1 \leq 3$
 $x_2 \leq 1$
 $x_3 \leq 1$
 $x_4 \leq 3$
 $x_5 \leq 1$
 $x_6 \leq 3$
 $x_7 \leq 1$
 $x_8 \leq 5$

$A_{ub} \cdot x \leq b_{ub}$
 \Updownarrow
 $l \cdot x \leq \text{capacity}$

capacity constraints

$A_{eq} \cdot x = b_{eq} = 0$

$0 = -x_1 + x_4 + x_5$
 $0 = -x_0 + x_2 + x_3$
 $0 = -x_3 - x_5 - x_6 + x_8$
 $0 = -x_2 - x_4 + x_6 + x_7$

flow conservation

maximum-flow.py

```
import numpy as np
from scipy.optimize import linprog

#           0  1  2  3  4  5  6  7  8
conservation = np.array([[ 0, -1,  0,  0,  1,  1,  0,  0,  0], # B
                        [-1,  0,  1,  1,  0,  0,  0,  0,  0], # C
                        [ 0,  0,  0, -1,  0, -1, -1,  0,  1], # D
                        [ 0,  0, -1,  0, -1,  0,  1,  1,  0]]) # E

#           0  1  2  3  4  5  6  7  8
sinks = np.array([0, 0, 0, 0, 0, 0, 0, 1, 1])

#           0  1  2  3  4  5  6  7  8
capacity = np.array([4, 3, 1, 1, 3, 1, 3, 1, 5])

res = linprog(-sinks,
              A_eq=conservation,
              b_eq=np.zeros(conservation.shape[0]),
              A_ub=np.eye(capacity.size),
              b_ub=capacity)

print(res)
```

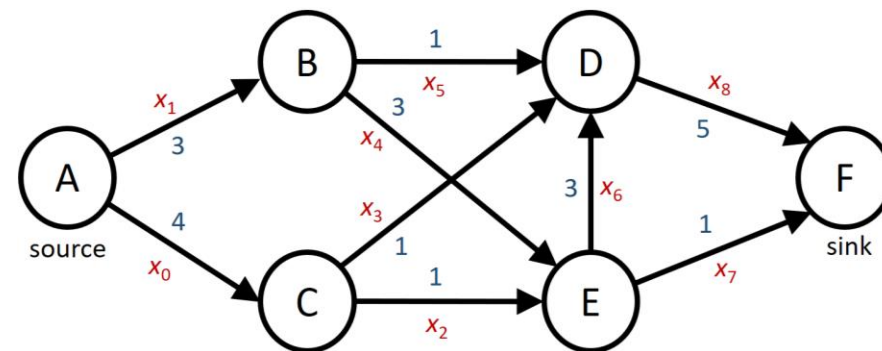

Python shell

```
| fun: -5.0
| message: 'Optimization terminated successfully.'
| nit: 9
| slack: array([2., 0., 0., 0., 1., 0., 1., 0., 1.])
| status: 0
| success: True
| x: array([2., 3., 1., 1., 2., 1., 2., 1., 4.])
```

the solution found varies
with the scipy version